

Instruction Manual PSE441



© halstrup-walcher GmbH

halstrup-walcher GmbH holds the copyright to this documentation.

Modification, expansion, duplication or disclosure to third parties is prohibited without prior consent from **halstrup-walcher GmbH**.

The data in this documentation specify products but do not guarantee product attributes.

halstrup-walcher GmbH - Stegener Straße 10 - 79199 Kirchzarten -

Tel.: +49 (0) 76 61 / 39 63 0 - Fax: +49 (0) 76 61 / 39 63 99

E-mail: info@halstrup-walcher.de - Internet: www.halstrup-walcher.com

Table of Contents

1	Safety precautions	5
1.1	Appropriate use	5
1.2	Shipping, assembly, electrical connections and start-up	5
1.3	Troubleshooting, maintenance, repairs, disposal	5
1.4	Symbols	6
2	Device description	7
2.1	Functions	7
2.2	Assembly	7
2.3	Jog keys.....	7
2.4	Position values.....	8
3	RS 485 interface	9
3.1	Interface parameters.....	9
3.2	Time response	9
3.3	Communication	9
3.3.1	Conventions	9
3.3.2	Daisy chain	9
3.3.3	Addressing	10
3.3.4	Data structure	11
3.3.5	Checksum	11
3.3.6	Data transfer error <sci-error>	11
3.4	Drive status.....	12
3.4.1	Error status <dev-error>	12
3.4.2	3.4.2 Motion status <motion-stat>	13
3.5	Commands	13
3.5.1	Read global status <GSTAT>	14
3.5.2	Read error status (<ERRSTAT>).....	14
3.5.3	Read status (<STAT>).....	15
3.5.4	Reset command (<RESET>).....	15
3.5.5	Start command	16
3.5.6	Stop command (<STOP>)	16
3.5.7	Set velocity mode (<VSET>)	17
3.5.8	Set positioning mode (<PSET>)	18
3.5.9	Set increment mode (<DELTASET>)	19
3.5.10	Enable jog mode (<ENABLE JOG>)	19
3.5.11	Leave jog mode (<LEAVE JOG>)	20
3.5.12	Read out software version (<SW VER>).....	20
3.5.13	Write or read the “address” parameter	21
3.5.14	Write or read the “position offset” parameter.	22
3.5.15	Parameter limit, counter clockwise (CCW).....	23
3.5.16	Parameter limit, clockwise (CW)	24
3.5.17	Serial settings parameter	25
3.5.18	AcTimeout parameter.....	26
3.5.19	Load default settings	27
4	Project design information	28
4.1	Mechanical design	28
4.2	Electrical design.....	29

4.2.1	Pin assignment	29
4.2.2	Communication via the HIPERDRIVE®-HUB.....	29
4.2.3	Communication via RS485	30
5	Technical data	32
5.1	Ambient conditions	32
5.2	Electrical data	32
5.3	Physical data	32
5.3.1	Dimension drawing	33
5.4	Motor speed – torque – operating current	34

Purpose of instruction manual

This instruction manual describes the features of the PSE 441 positioning system and provides guidelines for its use.

Improper use of these device or failure to follow these instructions may cause injury or damage equipment. All individuals responsible for operating this device must therefore be properly trained and aware of the hazards. The instruction manual, and in particular the safety precautions contained therein, must be followed carefully. **Contact the manufacturer if you do not understand any part of this instruction manual.**

Handle this manual with care:

- It must be readily available throughout the lifecycle of the device.
- It must be provided to any individuals who assume responsibility for operating the device at a later date.
- It must include any supplementary materials provided by the manufacturer.

The manufacturer reserves the right to continue developing this device model without documenting such development in each individual case. The manufacturer will be happy to determine whether this manual is up-to-date.

Conformity

This device is state of the art. It complies with the legal requirements of EC directives. This is shown by the CE mark.



© 2012

The manufacturer owns the copyright to this instruction manual, which contains technical data, instructions and drawings detailing devices features and handling guidelines. It must not be copied either wholly or in part or made available to third parties.

1 Safety precautions

1.1 Appropriate use

Positioning systems are especially suitable for automatically setting tools, stops or spindles for wood-processing equipment, packing lines, printing equipment, filling units and other types of special machines.

PSE441 positioning systems are not stand-alone devices and may only be used if coupled to another machine.

Compliance with the operating requirements—particularly the permissible supply voltage—indicated on the rating plate and in the “Technical data” is mandatory.

The device may only be handled as indicated in this manual. Modifications to the device are prohibited. The manufacturer is not liable for damages caused by improper use or failure to follow these instructions. Violations of this type render all warranty claims null and void.

This device is not designed for use in

- potentially explosive
- radioactive
- biologically or chemically contaminated environments!

1.2 Shipping, assembly, electrical connections and start-up

As soon as the device arrives, inspect it for any defects or **damage incurred from shipping**.

Handle the device with care, avoiding

- mechanical shocks/stresses
- moisture/dust infiltration
- the effects of aggressive gases, intense heat/cold, etc. on the device.

Assembly and the electrical connections should only be handled by properly trained professionals who have been authorized by the equipment operator.

The device may only be used by appropriately trained individuals who have been authorized by the equipment operator.

Specific safety precautions are given in individual sections of this manual.

1.3 Troubleshooting, maintenance, repairs, disposal

The individual responsible for the electrical connections must be notified immediately if the device is damaged or if errors occur.

This individual must take the device out of service until the error has been corrected and ensure that it cannot be used unintentionally.

This device requires no maintenance.

Only the manufacturer may perform repairs that require the housing to be opened.

The electronic components of the device contain environmentally hazardous materials and materials that can be reused. The device must therefore be sent to a recycling plant once it has been taken out of service. Compliance with country-specific environmental codes is mandatory.

1.4 Symbols

The symbols given below are used throughout this manual to indicate instances when improper operation could result in the following hazards:



WARNING!

This warns you of a potential hazard that could lead to bodily injury up to and including death if the corresponding instructions are not followed.



CAUTION!

This warns you of a potential hazard that could lead to significant property damage if corresponding instructions are not followed.



INFORMATION:

This indicates that the corresponding information is important for operating the device properly.

2 Device description

2.1 Functions

The PSE441 positioning system is an intelligent, compact, complete solution for positioning auxiliary and positioning axes. It consists of a motor, gear, power amplifier, control electronics, absolute measuring system and a serial RS485 interface. The integrated absolute measuring system eliminates the need for time-consuming reference runs. Use of a circular shaft and feather key makes assembly very easy. The positioning system is especially suitable for automatically setting tools, stops or spindles for wood-processing equipment, packing lines, printing equipment, filling units and other types of special machines. PSE441 positioning systems convert a digital positioning signal into an angle of rotation.

2.2 Assembly

Mount the PSE441 onto the machine by sliding the circular shaft of the positioning gear onto the axis to be driven and then securing it into place. A cylinder pin must be used as a locking mechanism for preventing further rotation (see section 4.1).

You must observe the following warnings in order to prevent damage to the drive during assembly:



Forces acting on the output shaft must not exceed the following values during assembly:

- max. radial: 50 N
- max. axial: 20 N



Do not run the PSE441 in reverse (do not attempt to turn the output shaft by applying an external force).

2.3 Jog keys

Use the jog keys to operate the drive without a control unit.

One of the following criteria must be met in order to use the jog keys:

- The drive is connected to a power supply but not yet exchanging data with the master.
- The drive is connected to a power supply, is communicating with the master and the master has activated the jog mode.

Briefly pressing one of the two jog keys (<500 ms) prompts the drive to move the output shaft by an increment of 0.1°. Pressing the key for longer (>500 ms) prompts the drive to operate at 40% of its maximum speed.

Jog 1: Drive rotates
counterclockwise (CCW)

Jog 2: Drive rotates clockwise
(CW)

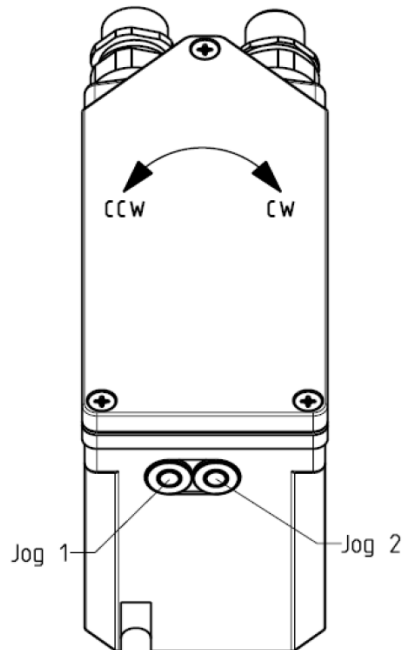

Holding both keys simultaneously for longer than 500 ms sets the actual drive position to 0.

2.4 Position values

For positive numbers, convert the position value to a hexadecimal number by multiplying the position by 65,536 (2^{16}) and following this with hexadecimal coding. Use the traditional 2's complement method for representing signed numbers when converting negative numbers, i.e., subtract the complementary number from the absolute hexadecimal value and add 1. Transfer the result as a 4-byte hexadecimal number (B4 is the byte with the highest value; B1 is the lowest).

Example: Converting a position to the corresponding hexadecimal number

Desired position: +32.785 rotations

Step 1

Multiply by $2^{16} = 65,536$

$32.785 * 2^{16} = 2,148,597.$ (see note 1)

Step 2

Convert to a hexadecimal number

$2,148,597(\text{dec}) = 0x00\ 20\ C8\ F5(\text{hex})$ (see note 2)

Step 3

Confirm

Whole rotations: $0x00\ 20(\text{hex}) = 32(\text{dec})$ rotations

Partial rotation: $0xC8\ F5(\text{hex}) = 51,445(\text{dec}) / 65,536 = 0.785$

Notes:

- The decimal places can be omitted when multiplying by 2^{16} .
- Always round the byte with the lowest value (B1) to zero, i.e. $0xC8\ F8$ becomes $0xC9\ 00$. This minimizes the final resolution (8 bits for one rotation) of the encoder with no computing time errors.

3 RS 485 interface

Follow the EIA-485-A standard (RS485) when setting up the physical interface that allows the PSE441 to communicate with its environment. This will enable communication with the drive without a HIPERDRIVE® HUB.

3.1 Interface parameters

The serial interface settings are as follows:

- Mode: half-duplex
- Baud rate: 38400
- Data bit: 8
- Stop bit: 1
- Parity: even

3.2 Time response

Communication with the PSE441 proceeds according to the master-slave principle, whereby the master (PLC, PC) sends a command to the slave (PSE441), which then acknowledges with an answer.

The drive considers a telegram to be over as soon as the master has gone 2 ms without sending a new byte (see section 3.5.17). The drive then interprets the data received and sends a response if applicable.

3.3 Communication

3.3.1 Conventions

Addresses, commands and parameters are enclosed in greater-than and less-than symbols, e.g., <address>, <STOP>. Abbreviated command names are written in capital letters; parameters are written in lower case.

Example: <**ADRCHANGE**, newadr>. The command for changing a current drive address is appended with the value of the new address (newadr).

Hexadecimal numbers (0-9, A-F) are identified by a preceding "0x", e.g., **0x3F**, which stands for the binary number 00111111.

Clockwise (CW) rotation of the drive is defined from the perspective of looking toward the motor drive shaft. Counter clockwise is designated by the abbreviation CCW.

3.3.2 Daisy chain

If multiple drives need to communicate with the master these should be connected to each other in series. If the drives are properly addressed, the master sends a message to all of the drives. The drives then interpret the received packet and the affected drive responds. The

preceding drives allow this to happen by switching their receiving direction. The figure below illustrates communication with drive 3:

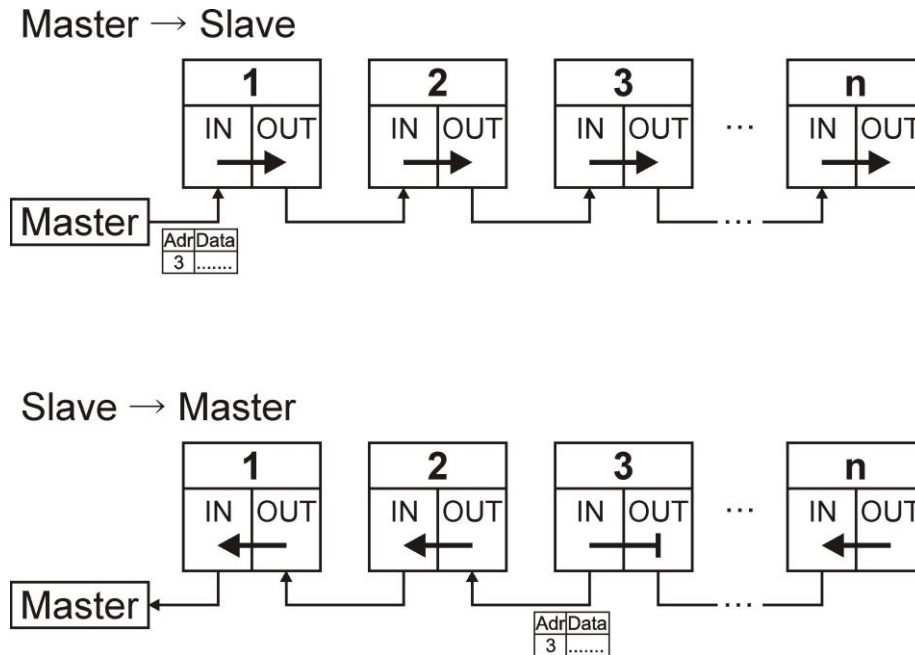

3.3.3 Addressing

Communication with each drive proceeds using its address. Up to 254 drives can be addressed. 0xFF is defined as a global address that can be used for addressing all drives for actions such as stopping all of the drives at once.

After switching on the PSE441, its address is always 254 (0xFE). Changes to this address are not saved permanently on the drive.

A drive with 0xFE as its address does not transmit received data to the next drive. This ensures that only the first drive with the address 0xFE in the daisy chain will respond to the request from the master.

Users wishing to change a drive's address after powering up must proceed as follows:

- Query the status of the 0xFE address. If a drive is present, it will respond.
- Send the new address.
- Send reset.
- Query the status of the new address. If the change succeeded, the drive will respond with the new address.

Users wishing to assign addresses to drives in a daisy chain after powering up must proceed as follows:

- Query the status of the 0xFE address. The first drive in the chain will respond.
- Send the new address.
- Send reset.
- Query the status of the new address. If the change succeeded, the drive will respond with the new address.
- Repeat the steps indicated above. The next drive under the 0xFE address will now respond.

3.3.4 Data structure

Commands sent from master to slave are structured as follows:

<address>	<COMMAND CODE>	<parameter 1...n> (optional)	<checksum>
1 byte	1...4 byte	0..8 byte	1 byte
at least 3 bytes, no more than 14 bytes			

The affected slave will respond as follows to every correct command:

<address>	<COMMAND CODE>	<sci-error>	<parameter 1...n> (optional)	<checksum>
1 byte	1 byte	2 byte	0..11 byte	1 byte
at least 5 bytes, no more than 16 bytes				

The affected drive first sends its own drive address, followed by the same command code that it received. If an error occurred during data transfer, <sci-error> will not be 0x00.

3.3.5 Checksum

Exclusive-or (EXOR) is used for calculating the checksum on a byte-by-byte basis. The result is the checksum with a length of one byte. This byte must be calculated by the party sending either the command or the response and then appended to the command/response sequence. In order to verify that the data were transferred correctly, the message recipient must perform the same operation (without a checksum, of course, i.e., without taking the final byte into account) and compare the result to the checksum received.

Example: <STOP> command to <address 0xFF>

Byte 1: <address>	0xFF	11111111
Byte 2: <STOP>	0x32	00110010
Checksum:	0xCD	11001101

Command byte sequence:

<address>	<STOP>	<checksum>
0xFF	0x32	0xCD

3.3.6 Data transfer error <sci-error>

The answer that the PSE441 sends for every command contains 2 bytes, which are used for indicating any potential drive or transfer errors. Both of these bytes will be 0x00 if all of the parameters have been transferred correctly and the drive status is error free. The following table lists the error bits and their meanings:

Notation		<sci-error>
Transfer sequence		<sci-error_high><sci-error_low>, <sci-err_h, sci-err_l>
<sci-error_low>	Bit 0	Framing, parity or overrun error
	Bit 1	Incorrect parameter value. Example: position limits exceeded, invalid percentage.
	Bit 2	Incorrect checksum
	Bit 3	Incorrect motion status or internal error bit set

	Bit 4	Incorrect number of characters.
	Bit 5	reserved
	Bit 6	Error bit set in error status byte <dev-error>.
	Bit 7	<START> command, but drive is not ready.
<sci-error_high>	Bit 0	Incorrect direction of rotation after blocking
	Bit 1	Invalid command
	Bit 2	reserved
	Bit 3	reserved
	Bit 4	reserved
	Bit 5	reserved
	Bit 6	reserved
	Bit 7	reserved

3.4 Drive status

3.4.1 Error status <dev-error>

The error status provides important information about the status of the drive. Errors can be deleted with a reset command (<RESET>).

Notation		<dev-error>
Transfer sequence		<dev-error_high>< dev-error_low>, <dev-err_h, dev-err_l>
<dev-error_low>	Bit 0	reserved
	Bit 1	Operating voltage below the limit (<17 V)
	Bit 2	Target position and actual position are not the same (drive rotated manually, actual position is outside of the positioning window).
	Bit 3	Temperature too high: drive stops
	Bit 4	CCW blocking: Response: drive stops, can only be moved CW.
	Bit 5	CW blocking: Response: drive stops, can only be moved CCW.
	Bit 6	reserved
	Bit 7	reserved
<dev-error_high>	Bit 0	Value of operating range limit counter clockwise <POSLIMCCW> exceeded. Response: drive stops, can be rotated CW.
	Bit 1	Value of operating range limit clockwise <POSLIMCW> exceeded. Response: drive stops, can be rotated CCW.
	Bit 2	reserved
	Bit 3	reserved
	Bit 4	Error in internal memory error
	Bit 5	reserved
	Bit 6	Position recording error
	Bit 7	Communication timeout. See section 3.5.18

3.4.2 3.4.2 Motion status <motion-stat>

The motion status provides important information on the current status of the drive motion.

Notation		<motion-stat>
Transfer sequence		<motion-stat_high><motion-stat_low>, <motion-stat_h, motion-stat_l>
<motion-stat_low>	Bit 0	reserved
	Bit 1	Velocity mode ready. The bit is "0" if the <VSET> command has been transferred correctly. The bit is reset after the <START> command.
	Bit 2	Position mode ready. The bit is "0" if the <PSET> or <DELTASET> command has been transferred correctly. The bit is reset after the <START> command.
	Bit 3	reserved
	Bit 4	reserved (always "1")
	Bit 5	The bit is set to "0" once the end position is reached. The value is "1" after a <START> command. This bit is not relevant in velocity mode.
	Bit 6	Velocity mode is active, i.e., a run is underway.
	Bit 7	Positioning mode is active, i.e., a run is underway. The bit remains set to "1" until the end position has been reached.
<motion-stat_high>	Bit 0	reserved
	Bit 1	Jog mode is active. The drive's jog keys have been enabled.
	Bit 2	Drive slows down.
	Bit 3	reserved
	Bit 4	reserved
	Bit 5	reserved
	Bit 6	reserved
	Bit 7	reserved

3.5 Commands

Notes:

- The drives will not respond if the global address (0xFF) is used for a command.
- The checksum in the following examples was calculated as described in section 3.3.5.
- In the following examples, <sci-error> is always indicated by a 0, which assumes that transfer has proceeded without error and that the drive status is error-free. If <sci-error> ≠ 0, errors occurred during transfer (see section 3.3.6).
- Please note that 1 million write cycles on the internal EEPROM memory are guaranteed. Further write cycles can cause errors. Permanent parameter write operations should be avoided for this reason.

3.5.1 Read global status <GSTAT>

Reading the global status provides the motion status (<motion-stat>), the actual position (<p>), the actual velocity (<v>), the temperature (<temp>) and the error status (<dev-error>).

Notation: <GSTAT>

Command code: 0x10

Values	Description	Bytes
<motion-stat>	Motion status (see section 3.4.2)	2
<p>	Actual position See section 2.4 for calculation	4
<v>	Actual velocity in rpm * 10 (ex.: 500 → 50 rpm)	2
<temp>	Actual temperature in °C	1
<dev-error>	Error status (see section 3.4.1)	2

Example:

Command:

<address>	<GSTAT>	<checksum>
0x01	0x10	0x11

Response:

<address>	<GSTAT>	<sci-error>	<motion-stat>	<p>
0x01	0x10	0x00 0x00	0x00 0x16	0x00 0x02 0x00 0x00

<v>	<temp>	<dev-error>	<checksum>
0x00 0x00	0x22	0x00 0x00	0x27

3.5.2 Read error status (<ERRSTAT>)

Reading this provides the error status (<dev-error>).

Notation: <ERRSTAT>

Command code: 0x11

Values	Description	Bytes
<motion-stat>	Motion status (see section 3.4.2)	2
<p>	Actual position See section 2.4 for calculations	4
<v>	Actual velocity in rpm * 10 (ex.: 500 → 50 rpm)	2
<temp>	Actual temperature in °C	1
<dev-error>	Error status (see section 3.4.1)	2

Example:

Command:

<address>	<ERRSTAT>	<checksum>
0x01	0x11	0x10

Response:

<address>	<ERRSTAT>	<sci-error>	<dev-error>	<checksum>
0x01	0x11	0x00 0x00	0x00 0x00	0x10

3.5.3 Read status (<STAT>)

Reading this status provides the motion status (<motion-stat>), the actual position (<p>), the actual velocity (<v>) and the temperature (<temp>).

Notation: <STAT>

Command code: 0x12

Values	Description	Bytes
<motion-stat>	Motion status (see section 3.4.2)	2
<p>	Actual position See section 2.4 for calculations	4
<v>	Actual velocity in rpm * 10 (ex.: 500 → 50 rpm)	2
<temp>	Actual temperature in °C	1

Example:

Command:

<address>	<STAT>	<checksum>
0x01	0x12	0x13

Response:

<address>	<STAT>	<sci-error>	<motion-stat>
0x01	0x12	0x00 0x00	0x00 0x16

<p>	<v>	<temp>	<checksum>
0x00 0x02 0x00 0x00	0x00 0x00	0x22	0x27

3.5.4 Reset command (<RESET>)

A reset command stops the motor immediately after the command is received and deletes existing errors in the error status (<dev-error>). Also, any previously sent address changes will take effect at this point.

Notation: <RESET>

Command code: 0x21

Example:

Command:

<address>	<START>	<checksum>
0x01	0x21	0x20

Response:

<address>	<START>	<sci-error>	<checksum>
0x01	0x21	0x00 0x00	0x20

3.5.5 Start command

The start command prompts the drive to start motion in the previously selected mode (velocity mode, position mode).

Notation: <START>
 Command code: 0x31

Example: Start command to drive address 0x05

Command:

<address>	<START>	<checksum>
0x05	0x31	0x34

Response:

<address>	<START>	<sci-error>	<checksum>
0x05	0x31	0x00 0x00	0x34

3.5.6 Stop command (<STOP>)

The stop command stops the drive (regardless of other circumstances).

Notation: <STOP>
 Command code: 0x32

Example: Stop command to drive address 0x05

Command:

<address>	<STOP>	<checksum>
0x05	0x32	0x37

Response:

<address>	<STOP>	<sci-error>	<checksum>
0x05	0x32	0x00 0x00	0x37

3.5.7 Set velocity mode (<VSET>)

In velocity mode, the drive is rotated (after the start command) in the desired direction <dir> and at the preset velocity <v%> regardless of its position, until it is stopped either by the stop command or by the reset command. The drive stops automatically once the position limits set by the <SET_POSLIMCW> or <SET_POSLIMCCW> command has been reached, provided the <limactive> parameter has not deactivated the limits.

Notation: <VSET, dir, v%, 0x00, limactive>
 Command code: 0x41 <dir> <v%> 0x00 <limactive>

Parameter	Description	Byte
<dir>	0x00 direction of rotation ccw 0x01 direction of rotation cw	1
<v%>	Motor speed in percent 1..12% → 5 rpm 13..18% → 10 rpm 19..24% → 15 rpm 25..31% → 20 rpm 32..37% → 25 rpm 38..43% → 30 rpm 44..49% → 35 rpm 50..55% → 40 rpm 56..62% → 45 rpm 63..68% → 50 rpm 69..74% → 55 rpm 75..80% → 60 rpm 81..86% → 65 rpm 87..93% → 70 rpm 94..99% → 75 rpm 100% → 80 rpm	1
<limactive>	0x00 <poslimitcw> and <poslimitccw> parameters are active 0x99 <poslimitcw> and <poslimitccw> parameters are not active	1

Example: CW run at 100% motor speed and inactive position limits

Command:

<address>	<VSET>	<dir>	<v%>	<>	<limactive>	<checksum>
0x01	0x41	0x01	0x64	0x00	0x99	0xBC

Response:

<address>	<VSET>	<sci-error>	<checksum>
0x01	0x41	0x00 0x00	0x40

3.5.8 Set positioning mode (<PSET>)

The <PSET> command sets the sends the data needed for the run, such as target position (<p>) and target velocity (<v%>). The start command sets the drive in motion, which then moves to the target position from whatever the current position is. The drive stops automatically as soon as it reaches the target position. A <STOP> or <RESET> command can be used to stop the drive in any given position. Please note that the target position always has to be within the limits defined by the <SET_POSLIMCW> and <SET_POSLIMCCW> commands.

Notation: <PSET, v%, 0x00, p>

Command code: 0x42 <v%> 0x00 <p>

Parameter	Description	Byte
<v%>	Motor speed in percent 1..12% → 5 rpm 13..18% → 10 rpm 19..24% → 15 rpm 25..31% → 20 rpm 32..37% → 25 rpm 38..43% → 30 rpm 44..49% → 35 rpm 50..55% → 40 rpm 56..62% → 45 rpm 63..68% → 50 rpm 69..74% → 55 rpm 75..80% → 60 rpm 81..86% → 65 rpm 87..93% → 70 rpm 94..99% → 75 rpm 100% → 80 rpm	1
<p>	Target position See section 2.4 for calculation	4

Example: Run to position 0x00020000 at 100% motor speed.

Command:

<address>	<PSET>	<v%>	<>	<p>	<checksum>
0x01	0x42	0x64	0x00	0x00 0x02 0x00 0x00	0x25

Response:

<address>	<PSET>	<sci-error>	<checksum>
0x01	0x42	0x00 0x00	0x43

3.5.9 Set increment mode (<DELTA SET>)

This command makes it possible to move from the current position by any freely defined number of rotations (delta) in either direction.

Notation: <DELTA SET, v%, 0x00, p>
 Command code: 0x44 <v%> 0x00 <p>

Parameter	Description	Byte
<v%>	Motor speed in percent 1..12% → 5 rpm 13..18% → 10 rpm 19..24% → 15 rpm 25..31% → 20 rpm 32..37% → 25 rpm 38..43% → 30 rpm 44..49% → 35 rpm 50..55% → 40 rpm 56..62% → 45 rpm 63..68% → 50 rpm 69..74% → 55 rpm 75..80% → 60 rpm 81..86% → 65 rpm 87..93% → 70 rpm 94..99% → 75 rpm 100% → 80 rpm	1
<p>	Position relative to the current position See section 2.4 for calculation	4

Example: Move +2 rotations at 100% motor speed

Command:

<address>	<DELTA SET>	<v%>	<>	<p>	<checksum>
0x01	0x44	0x64	0x00	0x00 0x02 0x00 0x00	0x23

Response:

<address>	<DELTA SET>	<sci-error>	<checksum>
0x01	0x44	0x00 0x00	0x45

3.5.10 Enable jog mode (<ENABLE JOG>)

The drive jog keys are locked if communication with the drive has already been set up. The keys can then no longer be used for running the drive. The drive must be switched to jog mode to enable the jog keys.

Notation: <ENABLE JOG, 0x01>
 Command code: 0x50 0x01

Example:

Command:

<address>	<ENABLE JOG>	<>	<checksum>
0x01	0x50	0x01	0x50

Response:

<address>	<ENABLE JOG>	<sci-error>	<motion-stat>
0x01	0x50	0x00 0x00	0x02 0x16

<>	<dev-error>	<checksum>
0x00 0x00	0x00 0x00	0x45

3.5.11 Leave jog mode (<LEAVE JOG>)

You must leave jog mode again in order to block the drive jog keys and return to operating the drive using the control unit.

Notation: <LEAVE JOG>

Command code: 0x51

Example:

Command:

<address>	<LEAVE JOG>	<checksum>
0x01	0x51	0x50

Response:

<address>	<LEAVE JOG>	<sci-error>	<motion-stat>	<checksum>
0x01	0x51	0x00 0x00	0x00 0x16	0x46

3.5.12 Read out software version (<SW VER>)

This command can be used to read out the software version, which is stored in 4 bytes as ASCII code.

Notation: <SW VER>

Command code: 0x70

Example:

Command:

<address>	<SW VER>	<checksum>
0x01	0x70	0x71

Response:

<address>	<SW VER>	<sci-error>	<sw-version>	<checksum>
0x01	0x70	0x00 0x00	0x32 0x2E 0x30 0x31	0x6C

The version of the drive software is therefore “2.01”

3.5.13 Write or read the “address” parameter

Default: 0xFE

3.5.13.1 Write

This command modifies the <adr> address of the drive. The address will not be saved permanently on the drive. After powering up, the drive address is always 0xFE.

A <RESET> command has to be sent after modifying the address to register the drive under the new address.

Command code: 0x81 0x22 0x00 0x01 0x00 <adr>

Example: Modifying the address from 0xFE to 0x01

Command:

<address>	<>	<adr>	<checksum>
0xFE	0x81 0x22 0x00 0x01 0x00	0x01	0x5D

Response:

<address>	<>	<sci-error>	<checksum>
0xFE	0x81	0x00 0x00	0x7F

3.5.13.2 Read

Two command-response sequences carried out in succession are used for reading out the address.

Command code 1: 0x82 0x22 0x00 0x01

Command code 2: 0x83

Example:

Command 1:

<address>	<>	<checksum>
0x01	0x82 0x22 0x00 0x01	0xA0

Response 1:

<address>	<>	<sci-error>	<checksum>
0x01	0x82	0x00 0x00	0x83

Command 2:

<address>	<>	<checksum>
0x01	0x83	0x82

Response 2:

<address>	<>	<sci-error>	<>	<adr>	<checksum>
0x01	0x83	0x00 0x00	0x22 0x00	0x01	0xA1

3.5.14 Write or read the “position offset” parameter.

Default: 0x00 0x00 0x00 0x00

3.5.14.1 Write

The current absolute position of the drive can be overwritten with any new value desired in order to adapt the drive data to circumstances specific to the equipment. The value is permanently recorded in the drive.

Command code: 0x81 0x24 0x00 0x04 <pos>

Example: Set actual position to 2 rotations

Command:

<address>	<>	<pos>	<checksum>
0x01	0x81 0x24 0x00 0x04	0x00 0x02 0x00 0x00	0xA2

Response:

<address>	<>	<sci-error>	<checksum>
0x01	0x81	0x00 0x00	0x80

3.5.14.2 Read

Two command-response sequences carried out in succession are used for reading out the position offset.

Command code 1: 0x82 0x24 0x00 0x04

Command code 2: 0x83

Example:

Command 1:

<address>	<>	<checksum>
0x01	0x82 0x24 0x00 0x04	0xA3

Response 1:

<address>	<>	<sci-error>	<checksum>
0x01	0x82	0x00 0x00	0x83

Command 2:

<address>	<>	<checksum>
0x01	0x83	0x82

Response 2:

<address>	<>	<sci-error>	<>	<pos>	<checksum>
0x01	0x83	0x00 0x00	0x24	0x00 0x02 0x00 0x00	0xA4

3.5.15 Parameter limit, counter clockwise (CCW)

Default: 0xFF 0x81 0x00 0x00 (-127 rotations)

The positioning limit (<poslimitccw>) defines the maximum operating range for counter clockwise operation. If the current position of the drive lies outside of the limit defined by the command, the drive can only move toward the position limit value.

3.5.15.1 Write

The value is permanently recorded in the drive.

Command code: 0x81 0x24 0x00 0x05 <poslimitccw>

Example: Setting the counter clockwise operating range to 0 rotations

Command:

<address>	<>	<poslimitccw>	<checksum>
0x01	0x81 0x24 0x00 0x05	0x00 0x00 0x00 0x00	0xA1

Response:

<address>	<>	<sci-error>	<checksum>
0x01	0x81	0x00 0x00	0x80

3.5.15.2 Read

Two command-response sequences carried out in succession are used for reading out the lower limit.

Command code 1: 0x82 0x24 0x00 0x05

Command code 2: 0x83

Example:

Command 1:

<address>	<>	<checksum>
0x01	0x82 0x24 0x00 0x05	0xA2

Response 1:

<address>	<>	<sci-error>	<checksum>
0x01	0x82	0x00 0x00	0x83

Command 2:

<address>	<>	<checksum>
0x01	0x83	0x82

Response 2:

<address>	<>	<sci-error>	<>	<poslimitccw>	<checksum>
0x01	0x83	0x00 0x00	0x24	0x00 0x00 0x00 0x00	0xA6

3.5.16 Parameter limit, clockwise (CW)

Default: 0x00 0x7F 0x00 0x00 (127 rotations)

The positioning limit (<poslimitcw>) defines the maximum operating range for clockwise operation. If the current position of the drive lies outside of the limit defined by the command, the drive can only move toward the position limit value.

3.5.16.1 Write

The value is permanently recorded in the drive.

Command code: 0x81 0x24 0x00 0x06 <poslimitcw>

Example: Setting the counterclockwise operating range to 100 rotations

Command:

<address>	<>	<poslimitcw>	<checksum>
0x01	0x81 0x24 0x00 0x06	0x00 0x64 0x00 0x00	0xC6

Response:

<address>	<>	<sci-error>	<checksum>
0x01	0x81	0x00 0x00	0x80

3.5.16.2 Read

Two command-response sequences carried out in succession are used for reading out the upper limit.

Command code 1: 0x82 0x24 0x00 0x06

Command code 2: 0x83

Example:

Command 1:

<address>	<>	<checksum>
0x01	0x82 0x24 0x00 0x06	0xA1

Response 1:

<address>	<>	<sci-error>	<checksum>
0x01	0x82	0x00 0x00	0x83

Command 2:

<address>	<>	<checksum>
0x01	0x83	0x82

Response 2:

<address>	<>	<sci-error>	<>	<poslimitcw>	<checksum>
0x01	0x83	0x00 0x00	0x24	0x00 0x64 0x00 0x00	0xC2

3.5.17 Serial settings parameter

Default: 0x96 0x00 0x00 0x14 (baud rate 38400; timeout 2.0 ms)

This parameter can be used for setting the baud rate (<baudrate>) and timeout (<timeout>) for accepting a command. Valid baud rates are 9600 (0x25 0x80), 19200 (0x4B 0x00) and 38400 (0x96 0x00). The timeout must be between 2 (0x00 0x14) and 20 (0x00 0xC8) ms (conversion factor = 10).

Changes are only accepted after a <RESET>.

3.5.17.1 Write

These values are permanently recorded in the drive.

Command code: 0x81 0x24 0x00 0x06 <poslimitcw>

Example: Setting the baud rate to 9600 and timeout to 2 ms

Command:

<address>	<>	<baudrate>	<timeout>	<checksum>
0x01	0x81 0x24 0x00 0x07	0x25 0x80	0x00 0x14	0x12

Response:

<address>	<>	<sci-error>	<checksum>
0x01	0x81	0x00 0x00	0x80

3.5.17.2 Read

Two command-response sequences carried out in succession are used for reading out the baud rate and the timeout.

Command code 1: 0x82 0x24 0x00 0x07

Command code 2: 0x83

Example:

Command 1:

<address>	<>	<checksum>
0x01	0x82 0x24 0x00 0x07	0xA0

Response 1:

<address>	<>	<sci-error>	<checksum>
0x01	0x82	0x00 0x00	0x83

Command 2:

<address>	<>	<checksum>
0x01	0x83	0x82

Response 2:

<address>	<>	<sci-error>	<>	<baudrate>	<timeout>	<checksum>
0x01	0x83	0x00 0x00	0x24	0x25 0x80	0x00 0x14	0x17

3.5.18 AcTimeout parameter

Default: 0x14 (2000 ms)

The AcTimeout parameter can be used for setting the time within the master must send a new telegram. If the drive does not receive a new telegram within this time, error bit 7 (<dev-error_high>) will be set and the drive stops. A <RESET> must be set in order to delete the error. Valid values for AcTimeout range from 0x01 (100 ms) to 0x64 (10000 ms); a value of 0xFF can be used for deactivating AcTimeout.

3.5.18.1 Write

The value is permanently recorded in the drive.

Command code: 0x81 0x22 0x00 0x0A 0x00 <actimeout>

Example: Deactivating AcTimeout

Command:

<address>	<>	<actimeout>	<checksum>
0x01	0x81 0x22 0x00 0x0A 0x00	0xFF	0x57

Response:

<address>	<>	<sci-error>	<checksum>
0x01	0x81	0x00 0x00	0x80

3.5.18.2 Read

Two command-response sequences carried out in succession are used for reading out the AcTimeout.

Command code 1: 0x82 0x22 0x00 0x0A

Command code 2: 0x83

Example:

Command 1:

<address>	<>	<checksum>
0x01	0x82 0x22 0x00 0x0A	0xAB

Response 1:

<address>	<>	<sci-error>	<checksum>
0x01	0x82	0x00 0x00	0x83

Command 2:

<address>	<>	<checksum>
0x01	0x83	0x82

Response 2:

<address>	<>	<sci-error>	<>	<actimeout>	<checksum>
0x01	0x83	0x00 0x00	0x22 0x00	0xFF	0x17

3.5.19 Load default settings

This command loads the default settings. The following parameters are set to their defaults:

- Position offset
- Counterclockwise limit
- Clockwise limit
- AcTimeout

Rotations (the two higher value bytes) for the actual position are set to 0x00 0x00. The two lower value bytes for the actual position indicate the original position of the output shaft upon delivery.

Command code: 0x81 0x24 0x00 0x09 0xAA 0xCC 0x11 0x55

Example: Deactivating AcTimeout

Command:

<address>	<>	<checksum>
0x01	0x81 0x24 0x00 0x09 0xAA 0xCC 0x11 0x55	0x57

Response:

<address>	<>	<sci-error>	<checksum>
0x01	0x81	0x00 0x00	0x80

4 Project design information

4.1 Mechanical design

Mounting the PSE441 onto a machine requires a hollow shaft with a clamping collar, as well as a locking mechanism to prevent rotation. The corresponding dimensions can be found in the drawing below.

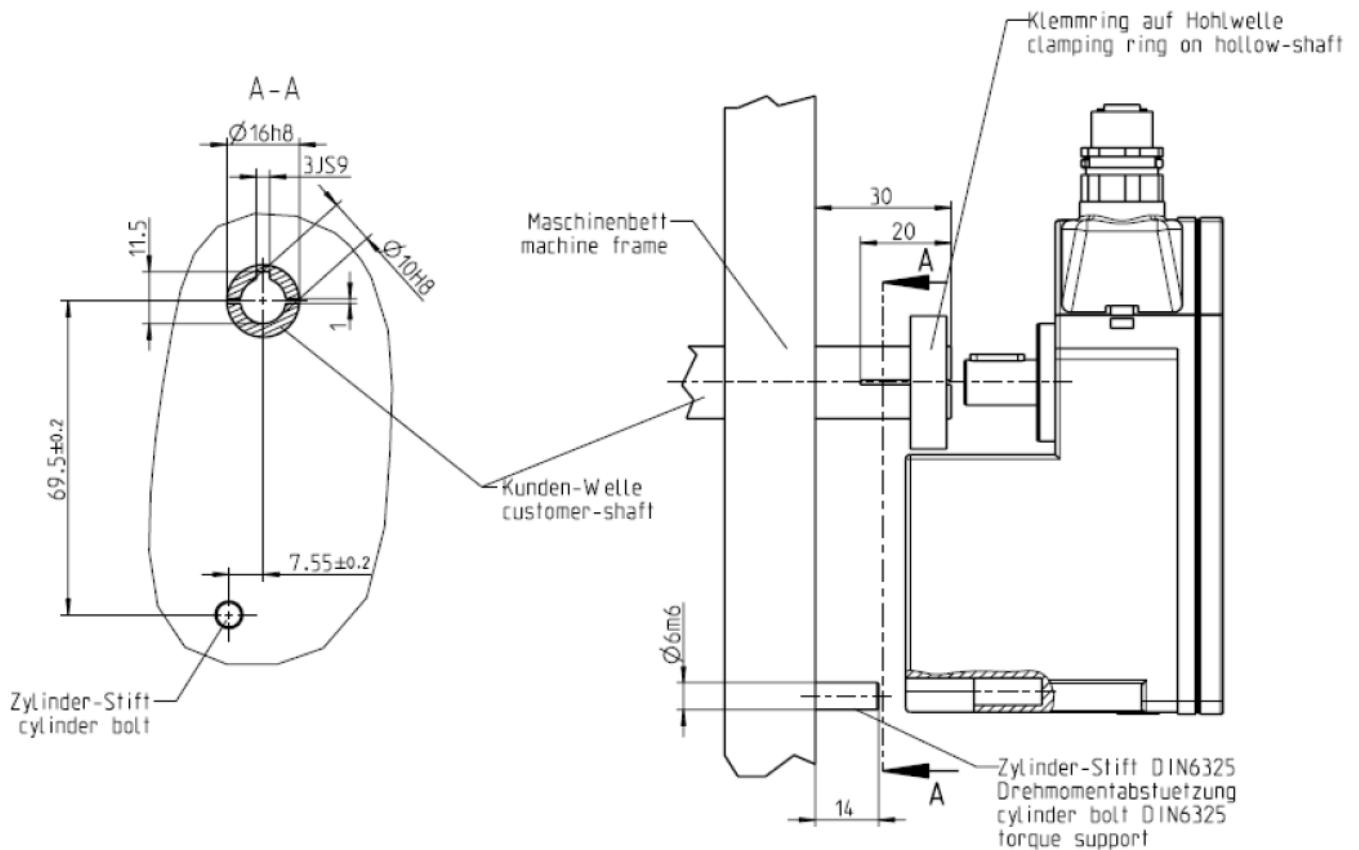

The instructions below must be followed when designing the mechanical layout of your system:



Never apply force to the housing cover, e.g., for supporting weight.



The physical mount and locking mechanism must be designed in a way that avoids any additional load on the output shaft.



Forces acting on the output shaft must not exceed the following values during assembly:

- max. radial: 50 N
- max. axial: 20 N



Do not run the PSE441 in reverse (i.e., do not attempt to turn the output shaft by applying an external force).

4.2 Electrical design

4.2.1 Pin assignment

Input (M12 male connector)

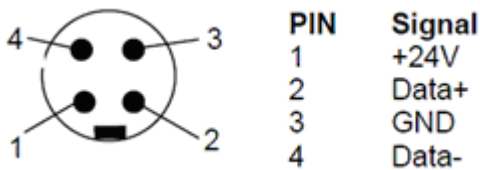

Output (M12 female connector)

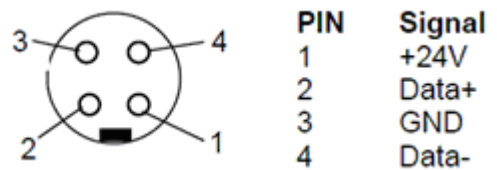

The appropriate female input connector and the male output connector can both be ordered (order numbers 9601.0144 and 9601.0152, respectively).



If you do not use the output port, cover it with a plastic cover.



EN 60204-1 stipulates that the voltage loss within the cable may not exceed 5% of the nominal voltage (1.2 V).



The PSE441 connections are designed for a maximum current of 4 A (40°C). Current must not exceed this value.

4.2.2 Communication via the HIPERDRIVE®-HUB

Up to 8 PSE441 units can be operated on one HIPERDRIVE®-HUB. Please see our website for more information on the HUB.

We recommend connecting the drives to the HUB using the following prefabricated cable: M12 female connector, A-coded, with 4 x 0.34 mm² cables, shielded

The HUB pin assignment is as follows:

PSE441 pin	HUB pin	Signal
1	3 or 5	+24V
2	1	Data+
3	4 or 6	GND

4	2	Data-
---	---	-------

Please make a common earth connection for:



- the earth connection of the HIPERDRIVE®-HUB
- all power supply housings
- cable shields from the line leading to the PSE441
- ground lines of the power supply (if necessary)

Please follow the recommendations given in DIN EN 60204-1.

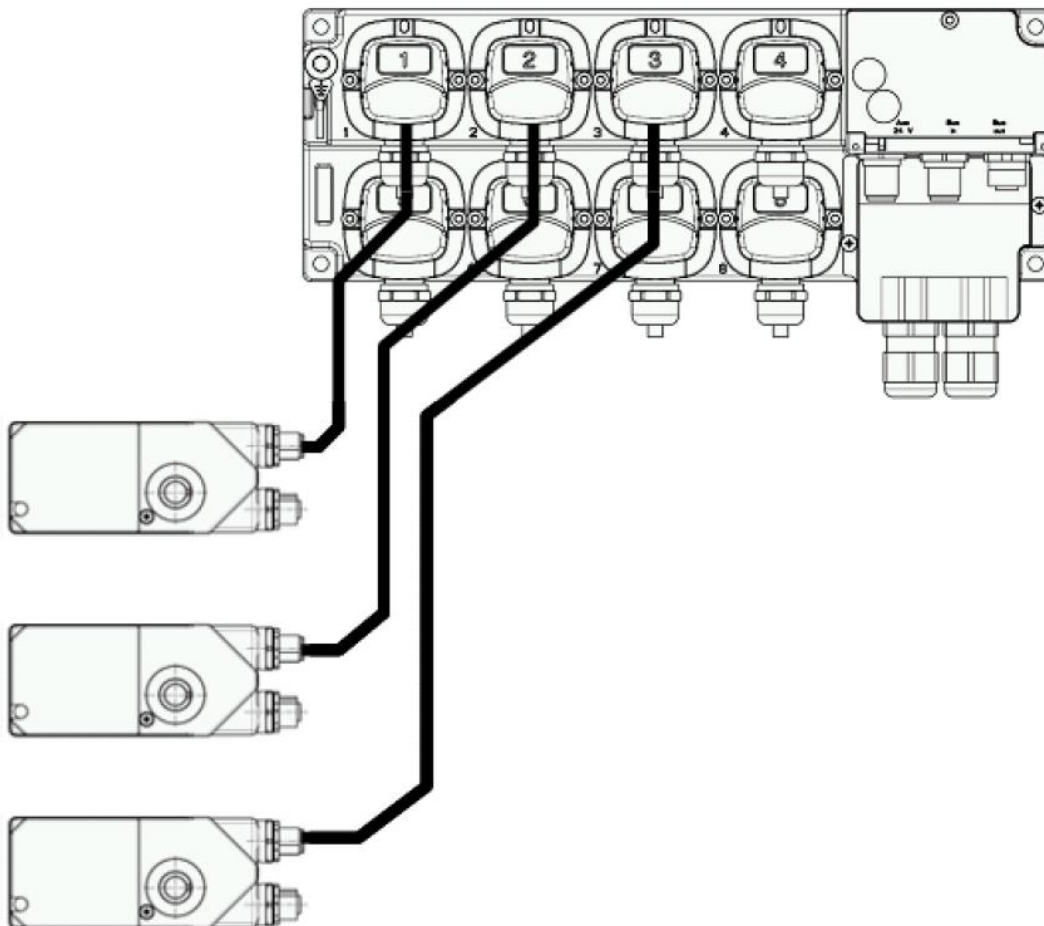

4.2.3 Communication via RS485

Communication with the drives can also proceed without a HUB. The physical interface that allows the PSE441 to communicate with its environment is conform to the EIA-485-A standard (RS485).

If several of these drives are present, connect them together in series (daisy chain). This connection is a point-to-point connection.

We recommend the following cable for connecting between drives and/or to the master:

2 x 0.75 mm² (power supply) + 2 x 0.34 mm² (bus), shielded

Please make a common earth connection for:



- all power supply housings
- cable shields for the line leading to the PSE441
- ground lines for the power supply (if necessary)

Please follow the recommendations given in DIN EN 60204-1.

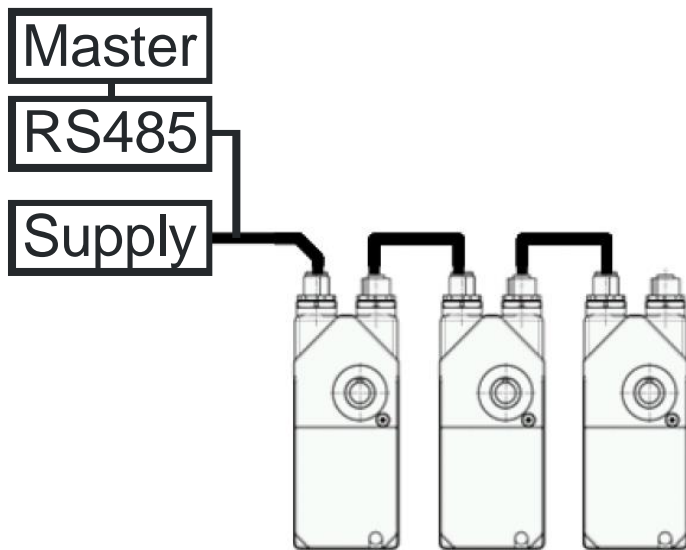

The PSE441 connections are designed for a maximum of 4 A (40°C), which means that 5 drives can be operated simultaneously. In order to use more than 5 drives on a single line, you should operate the drives on a time delay or change the operating point (see section 5.4).

5 Technical data

5.1 Ambient conditions

Ambient temperature	+10 ... +45 °C
Storage temperature	-10 ... +70 °C
Shock resistance as specified in EN 60068-2-27	50 g 9 ms
Vibration resistance as specified in EN 60068-2-6	10 Hz 0.3 g 30 Hz 2.8 g 60, 100, 500, 1000 Hz 10 g Continuous operation in the 5 ... 2000 Hz range, max. 5 g
EMC standards Conformity	CE CE declaration of conformity available upon request
IEC 60529 protection class with installed mating connectors	IP 65
Relative humidity	90% (no condensation)
Start-up time as specified in EN 60034-1	S2 30% (basis time 300 s)

5.2 Electrical data

Nominal power output	6 W
Supply voltage	24 VDC ±10%
Nominal current	0.8 A
Positioning accuracy	± 2.5 °
Min. positioning increment	1.4 °
Interface	EIA-485-A (RS485)
Absolute value acquisition	magnetic, 256 rotations

5.3 Physical data

Max. torque	2.5 Nm (at 24 VDC)
Holding torque	min. 0.1 Nm
Max. motor speed	80 rpm
Positioning range	250 rotations, no mechanical limits.
Dimensions	see drawing
Weight (approx.)	600 g
Maximum axial/radial force	0 N (see project design information)

5.3.1 Dimension drawing

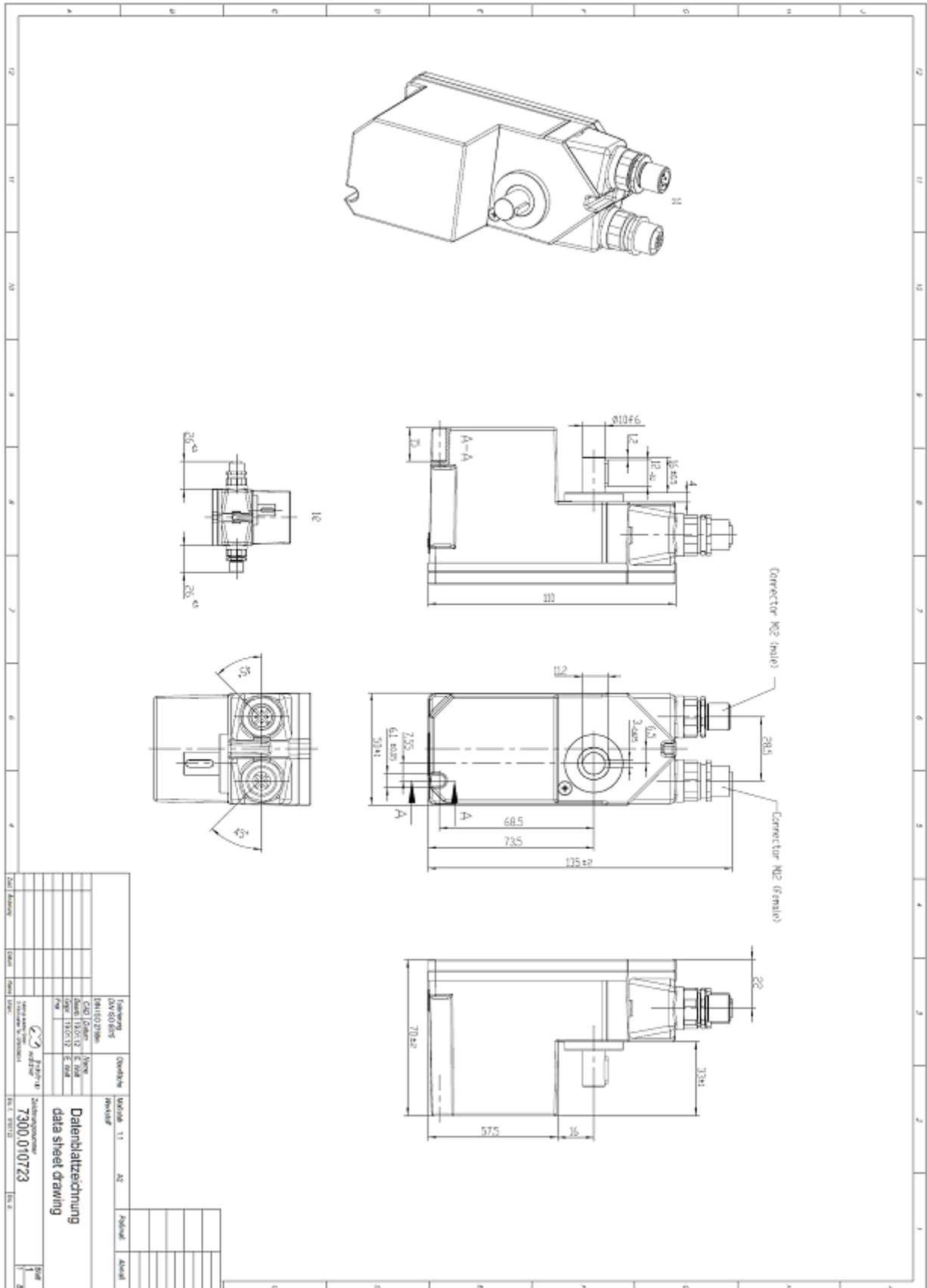

5.4 Motor speed – torque – operating current

